



Making **BETTER** ICT Solutions

Software | Hardware | Services





Our Mission

We strive to improve the value of our clients' businesses by deploying responsive, resilient and scalable IT and communication solutions.

Our Vision

We work upward to be the industry's preferred provider of responsive IT solutions, driven by the confidence of our expanding client network.

Accelerating your Digital Transformation



Best-in-class

We deploy only the best ICT software and hardware for your needs.



Customization

We scope your actual business requirements and translate them to responsive, resilient and scalable ICT solutions.



Maintenance and Support

Our dedicated team provides proactive, timely, effective support and maintenance so you can keep using our solutions sustainably.



Why work with us?

- 01 Access cutting-edge IT and communication solutions that evolve with your needs.
- 02 Stay agile with solutions designed to adapt quickly to changes and challenges.
- 03 Grow your business with solutions that expand as your business does.
- 04 Receive customized services that directly address your unique business requirements.
- 05 Stay ahead of the competition with innovative solutions designed to keep you ahead of industry trends.
- 06 Focus on growing your business while we handle the technology that supports your success.
- 07 Achieve Strong Profit Margins and Accelerate Growth with RVN.

HISTORY OF RVN

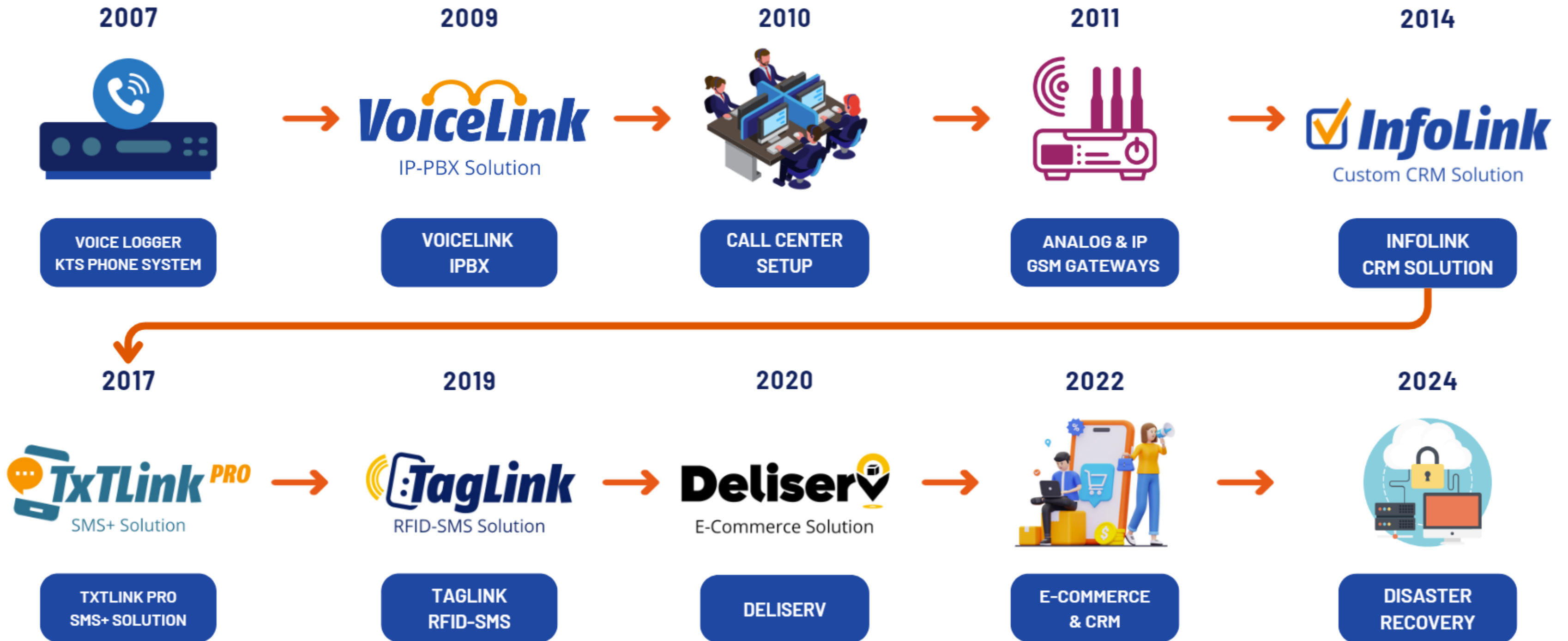



Our Confident Clients



<dev/>

Our versatile team of developers help you create and deploy the best ICT software for your needs. RVN is helping businesses accelerate their digital transformation and growth.



Web App Development



Mobile App Development



**Application Programming
Interface (API) Integrations**



Website Development

Our Process



Our Resilient Hardware



IP and Analog GSM Gateways



IP, Digital and Analog Call Recorders



Analog Trunk and Extension Gateways



IP, Digital, Analog and Conference Phones



CCTV Systems



Biometrics and Access Control Systems

Our Best-in-Class Services



System Maintenance &
Support



Cloud Services



IT Infrastructure Design
and Deployment



Disaster Recovery Plan
(DRP)



Structured Network
Cabling



Cabling Testing and
Certification



**TECHNOLOGY
SOLUTIONS**



Inventory Management Solution



Property Management Solution



Project Management Solution



IP-PBX Solution



RFID-SMS Solution



Custom CRM Solution



OmniChannel Chat Solution



Queuing Management Solution



Hospital Management Solution



Events Management Solution



Training Management Solution



Auto-Dialer Solution



E-Commerce Solution



Ticket Management Solution



School Management Solution



Branded SMS SaaS



E-Government Solutions



SMS+ Solution

 **InfoLink**
Custom CRM Solution





What is Infolink?

Infolink is a fully customizable Customer Relationship Management (CRM) solution tailored to meet the unique needs of your business. Unlike off-the-shelf CRMs, Infolink adapts to your workflows, processes, and goals, providing a personalized system that truly aligns with your operations. At RVN, we don't just offer a CRM; we create a solution that empowers your team and enhances your customer relationships. Customization is our edge.





Features

- Tailored CRM Modules - Customizable dashboards, reports, and workflows to match your business processes.
- Scalable Design - Built to grow with your business, whether you're a startup or an enterprise.
- Integration Ready - Seamlessly integrates with your existing tools and platforms.
- User-Friendly Interface - Intuitive design that requires minimal training for your team.
- Real-Time Analytics - Track performance and customer behavior with dynamic reports and insights.
- Enhanced Security - Data protection and role-based access to safeguard sensitive information.
- Mobile Accessibility - Manage your CRM on the go with a responsive mobile interface.



Benefits of Infolink

- Customized to Fit Your Business – Unlike generic CRMs, Infolink is built specifically for your unique needs, ensuring maximum efficiency and relevance.
- Improved Productivity – Streamlined workflows and automation reduce manual tasks, saving time for your team.
- Better Customer Insights– Gain a deeper understanding of your customers, enabling personalized and effective communication.
- Increased ROI – Tailored features mean no paying for unnecessary tools—just what your business truly needs.
- Seamless Collaboration – Boost team collaboration with shared data, tasks, and real-time updates.
- Future-Ready – Scalable and flexible, Infolink evolves as your business grows.

VoiceLink
IP-PBX Solution





What is VoiceLink?

VoiceLink is a cloud-based IP-PBX system that enhances business communication through reliable VoIP technology. It offers scalable and cost-effective telephony solutions.

Features:

- VoIP-enabled calling
- Interactive Voice Response (IVR)
- Call forwarding and routing
- Call analytics and reporting



Benefits:

- Reduce communication costs
- Improve customer service with IVR
- Ensure uninterrupted connectivity
- Track and analyze call performance



TxTLink SaaS
Branded SMS SaaS

Instant Reach, Infinite Flexibility





What is TxtLink SaaS

- 01 A cloud-based SMS broadcasting solution
- 02 Designed for businesses to send bulk SMS messages efficiently.

Benefits of TxtLink SaaS

- 01 **Cost Efficiency**
 - Lower overall costs compared to traditional models
- 02 **Scalability**
 - Easily scale messaging as needed
- 03 **Flexibility**
 - Use credits as needed, with no rush to use them

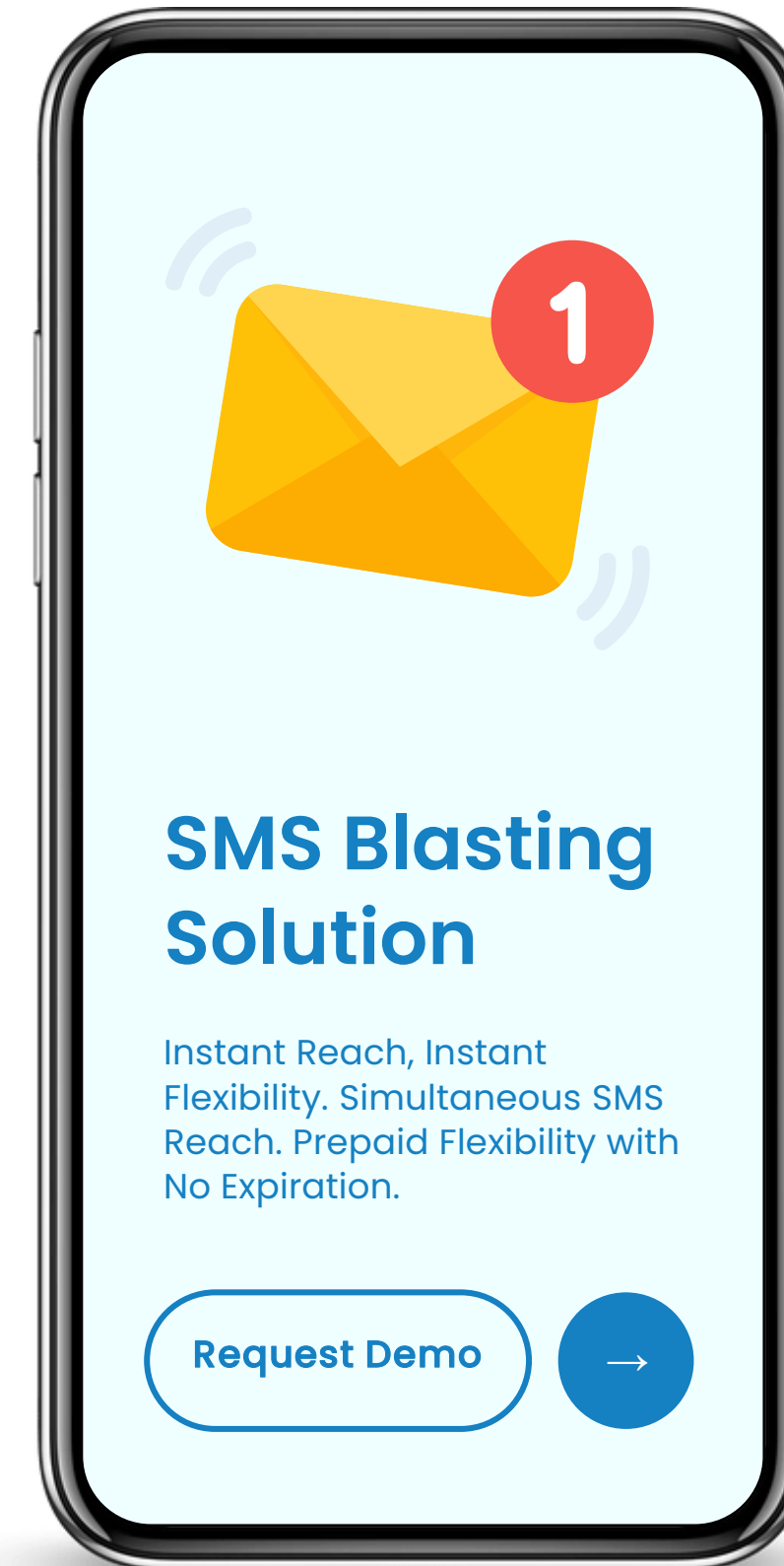

How it works



01

User-Friendly Dashboard

- Intuitive interface for easy message creation

02

Bulk Uploads

- Import contact lists for large campaigns

03

Real-Time Reporting

- Track delivery status and response rates

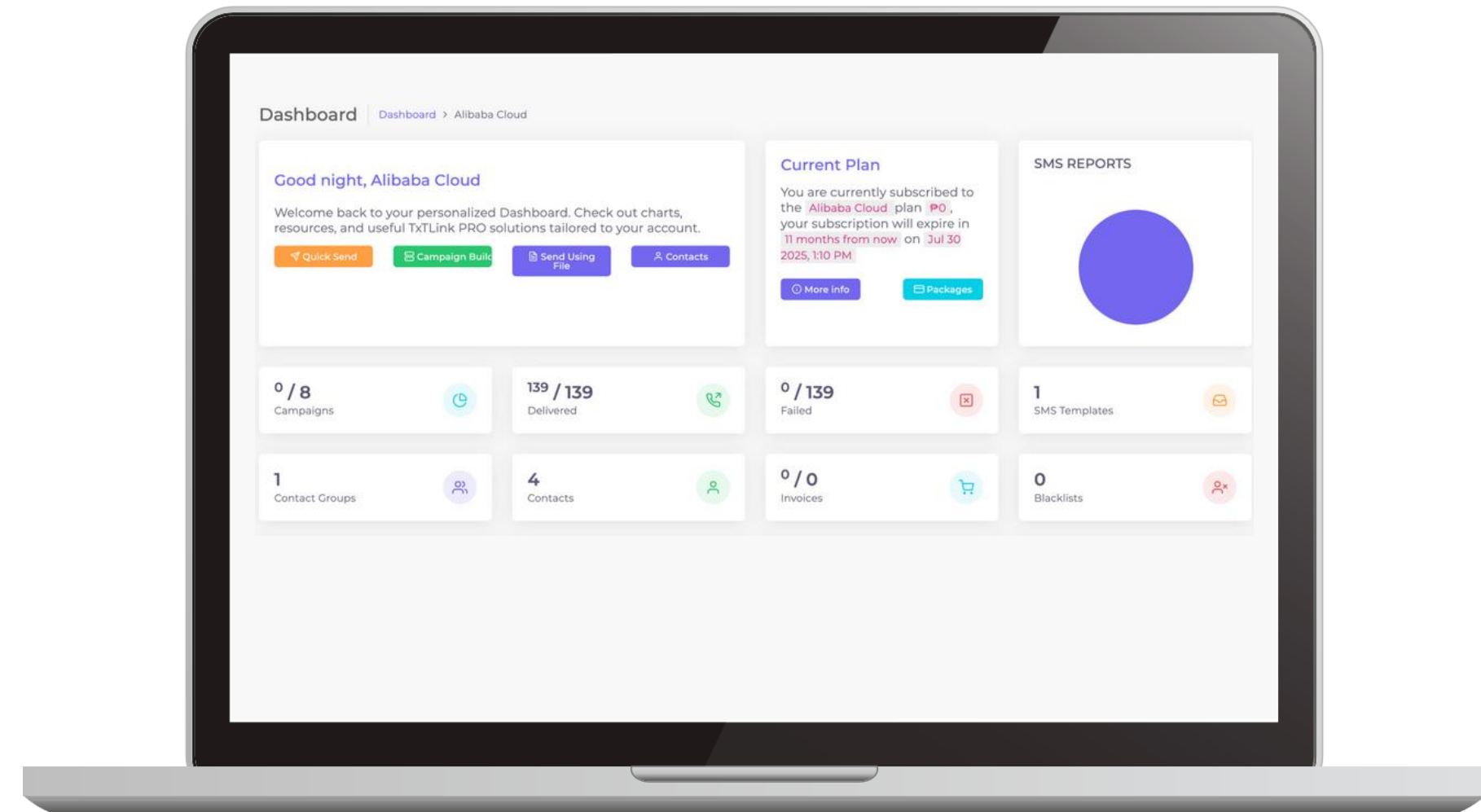

Pricing Model of **TxTLink** SaaS Branded SMS SaaS

01 Overview of Pay-Per-Use Pricing

- Transparent and competitive rates
- No hidden fees

02 Examples of Cost Savings

- Comparison with traditional SMS services

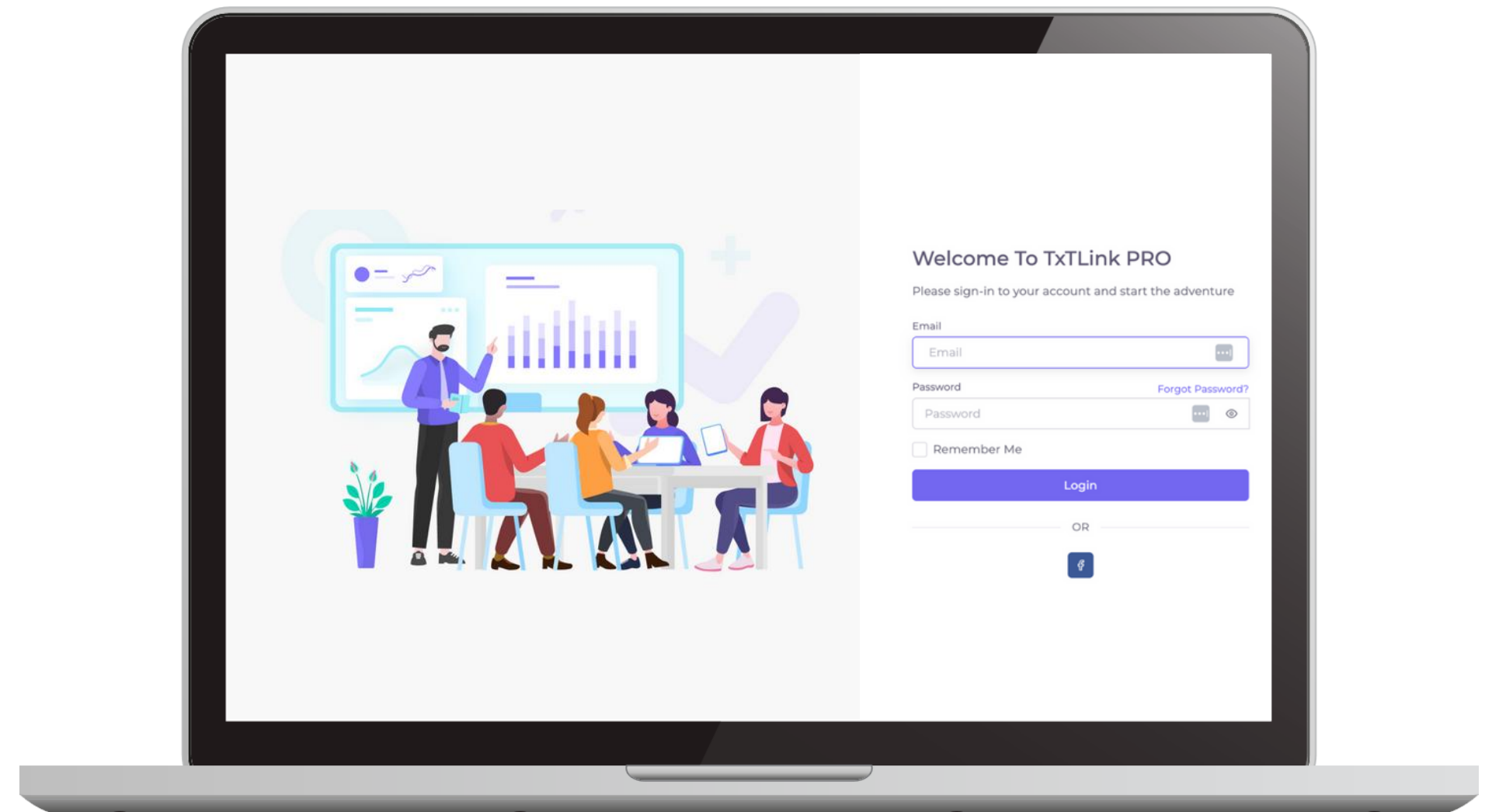



TxTLink SaaS

Branded SMS SaaS

Instant Reach, Infinite Flexibility





What is TxtLink SaaS

- 01 A cloud-based SMS broadcasting solution
- 02 Designed for businesses to send bulk SMS messages efficiently.

Benefits of TxtLink SaaS

- 01 **Cost Efficiency**
 - Lower overall costs compared to traditional models
- 02 **Scalability**
 - Easily scale messaging as needed
- 03 **Flexibility**
 - Use credits as needed, with no rush to use them

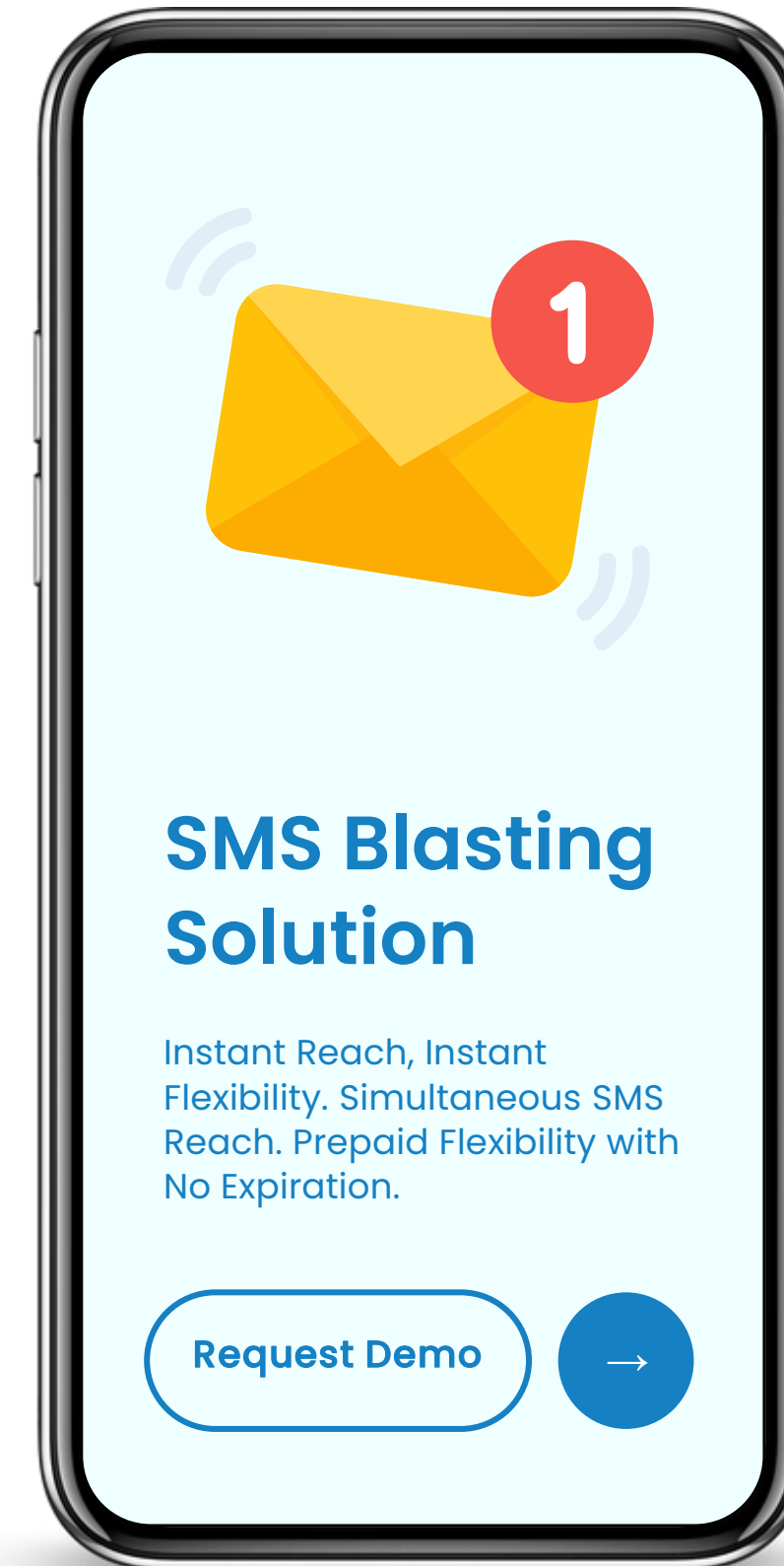

How it works



01

User-Friendly Dashboard

- Intuitive interface for easy message creation

02

Bulk Uploads

- Import contact lists for large campaigns

03

Real-Time Reporting

- Track delivery status and response rates

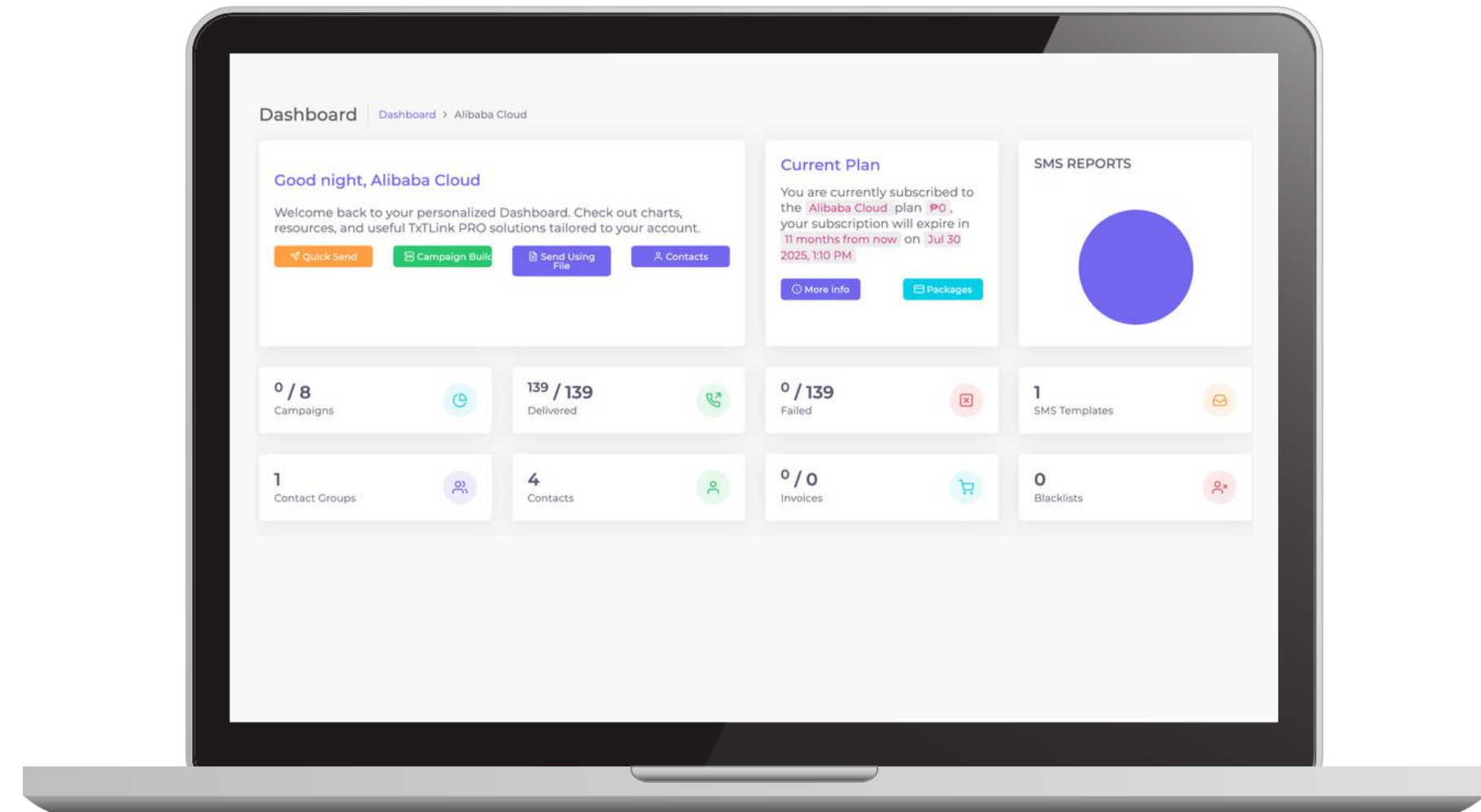

Pricing Model of Branded SMS SaaS

01 Overview of Pay-Per-Use Pricing

- Transparent and competitive rates
- No hidden fees

02 Examples of Cost Savings

- Comparison with traditional SMS services

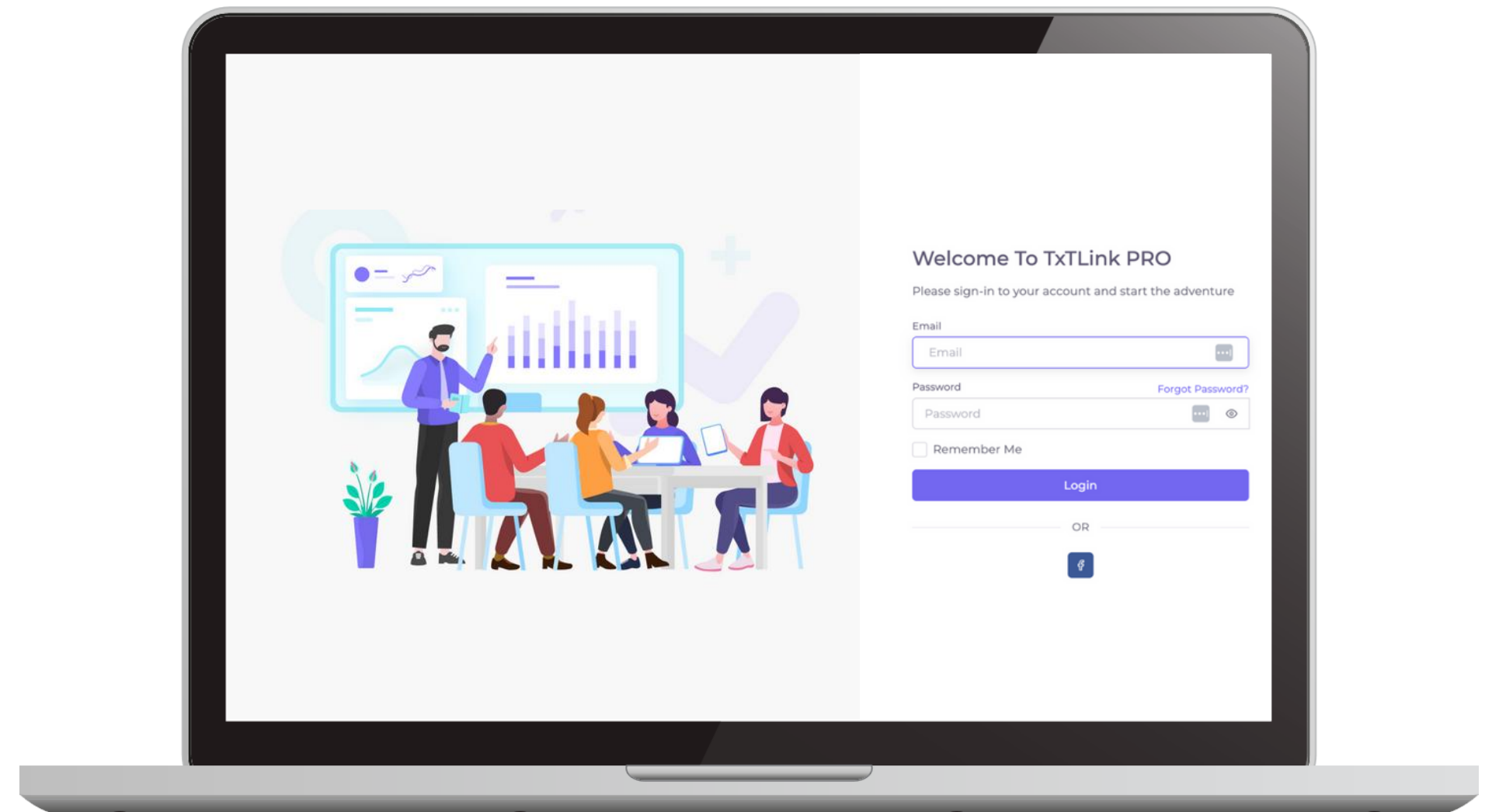



OmniLink
OmniChannel Chat Solution

Connect. Engage. Succeed with Omnilink



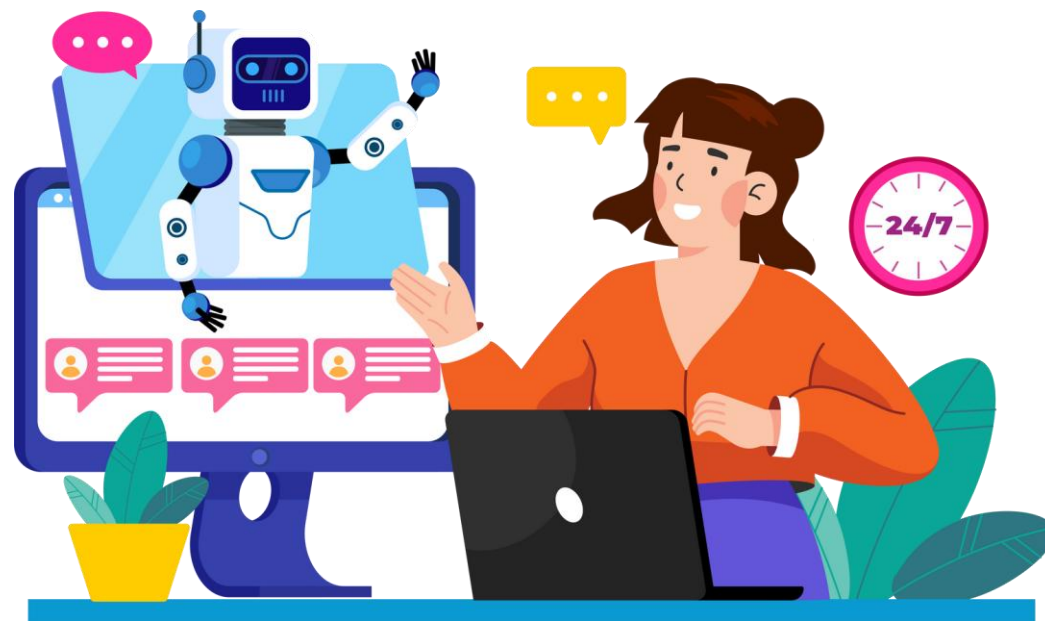

Omnilink is a state-of-the-art omnichannel chat solution that unifies customer communication across platforms like social media, messaging apps, and websites into one seamless interface. With integrated AI-powered chatbots, Omnilink automates routine interactions, provides instant responses, and enhances customer engagement 24/7. Combining human-like AI assistance with real-time updates and powerful analytics, Omnilink empowers businesses to deliver personalized, efficient, and meaningful customer experiences across all channels.



Features:

- Integration with email, SMS, and social media platforms
- AI chatbot support for quick responses
- Customer conversation history tracking
- Analytics and reporting tools



Benefits:

- Provide faster and consistent customer support
- Centralize communications for efficiency
- Reduce response times with automation
- Improve customer satisfaction and retention



ECOMMERCE AND LOGISTICS SOLUTIONS



Deliserv

E-Commerce Solution

DeliServ E-commerce and Logistics Solution is a comprehensive platform that not only streamlines online buying and selling but also integrates seamless logistics management to deliver a complete end-to-end solution for businesses. This platform empowers businesses to manage their virtual storefronts and optimize order fulfillment, ensuring smooth operations from purchase to delivery.

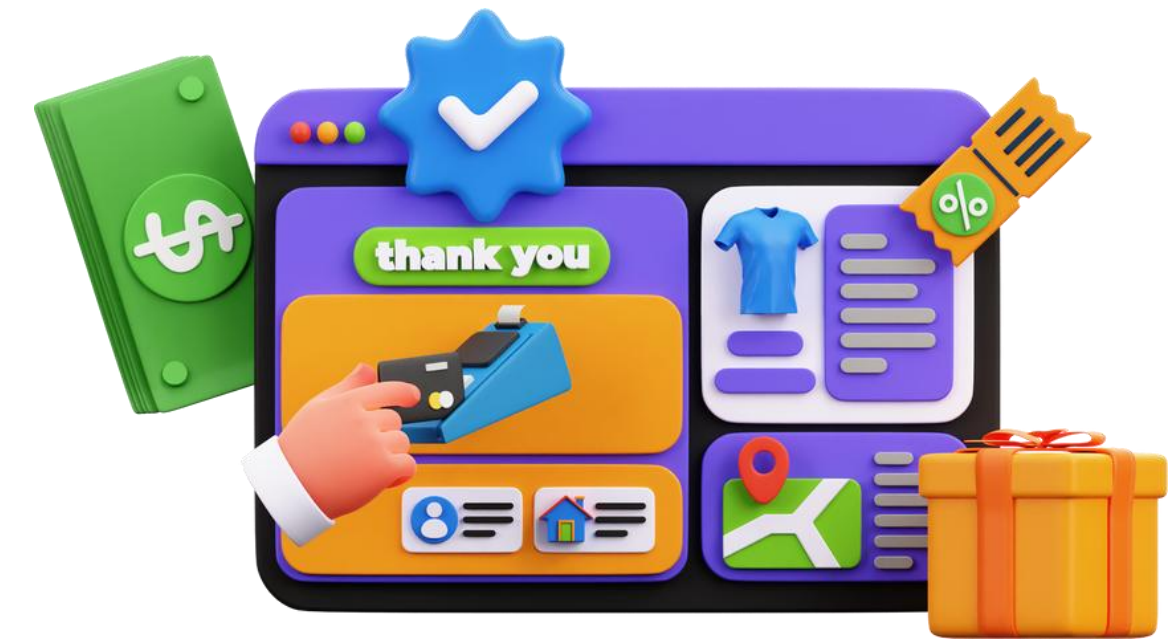

Ecommerce Features:

- Dynamic Catalog: Showcase products with customizable descriptions, quality images, and real-time pricing.
- Easy Cart: Simplifies item selection, review, and purchase management.
- User Accounts: Enable order tracking, updates, and personalized preferences.
- Smart Search: Advanced filters and predictive browsing for quick product discovery.
- Secure Payments: Supports multiple safe and fast payment options.
- Order Management: Tracks shipments, handles returns, and streamlines the process.



E-Commerce Solution

Logistics Features:

- Integrated Logistics Management: Automates inventory tracking, shipment processing, and delivery updates to optimize fulfillment.
- Real-time Order Tracking: Keep customers and businesses updated with live tracking of orders and deliveries.
- Smart Route Optimization: Reduces delivery times and costs by automatically planning efficient delivery routes.
- Fleet Management: Manage transportation assets, drivers, and schedules for timely and reliable deliveries.
- Warehouse Integration: Sync



- Dynamic Catalog: Showcase products with customizable descriptions, quality images, and real-time pricing.
- Easy Cart: Simplifies item selection, review, and purchase management.
- User Accounts: Enable order tracking, updates, and personalized preferences.
- Smart Search: Advanced filters and predictive browsing for quick product discovery.
- Secure Payments: Supports multiple safe and fast payment options.
- Order Management: Tracks shipments, handles returns, and streamlines the process.

ProjectLink
Project Management Solution



ProjectLink empowers teams to manage projects effectively from start to finish. It offers tools for task tracking, collaboration, and progress visualization.

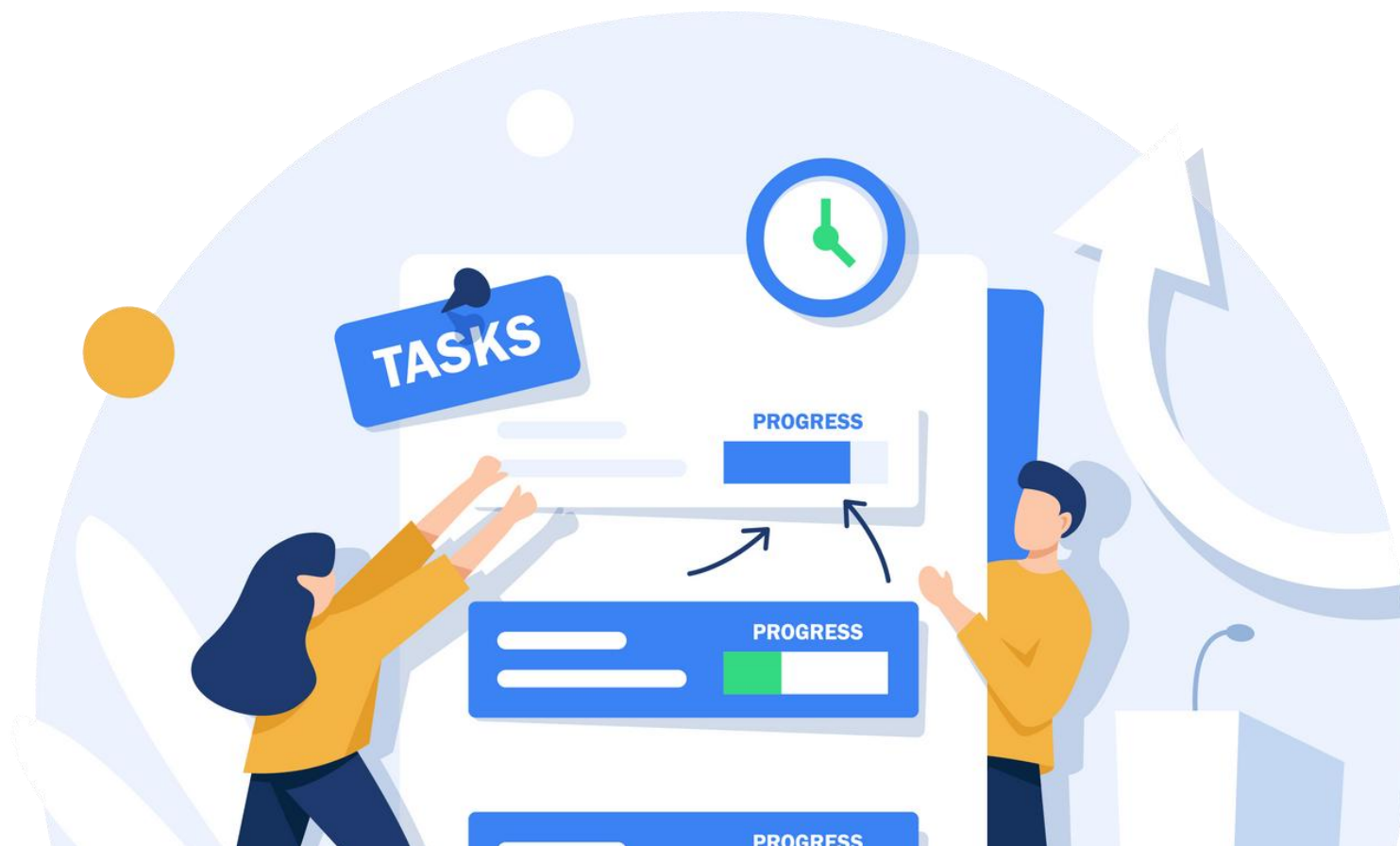

Features:

- Task assignment and tracking
- Gantt chart visualization for timelines
- Real-time project updates
- Collaboration tools for teams



Benefits:

- Ensure projects stay on schedule
- Enhance team collaboration and communication
- Monitor progress with ease
- Boost productivity and resource efficiency

Gov  Link
E-Government Solutions





GovLink is a digital platform that simplifies access to public services and enhances communication between citizens and local governments. It addresses challenges like long queues, slow issue resolution, and limited civic engagement through features such as:

- Real-time updates on announcements, infrastructure projects, and emergencies.
- Event calendars, tourism guides, and visual galleries of city activities.
- An E-Marketplace to support local businesses and job listings for employment opportunities.
- Online permit applications for hassle-free processing.

GovLink promotes transparency, efficiency, and community connection, making it easier for citizens to engage with their government and access essential services.

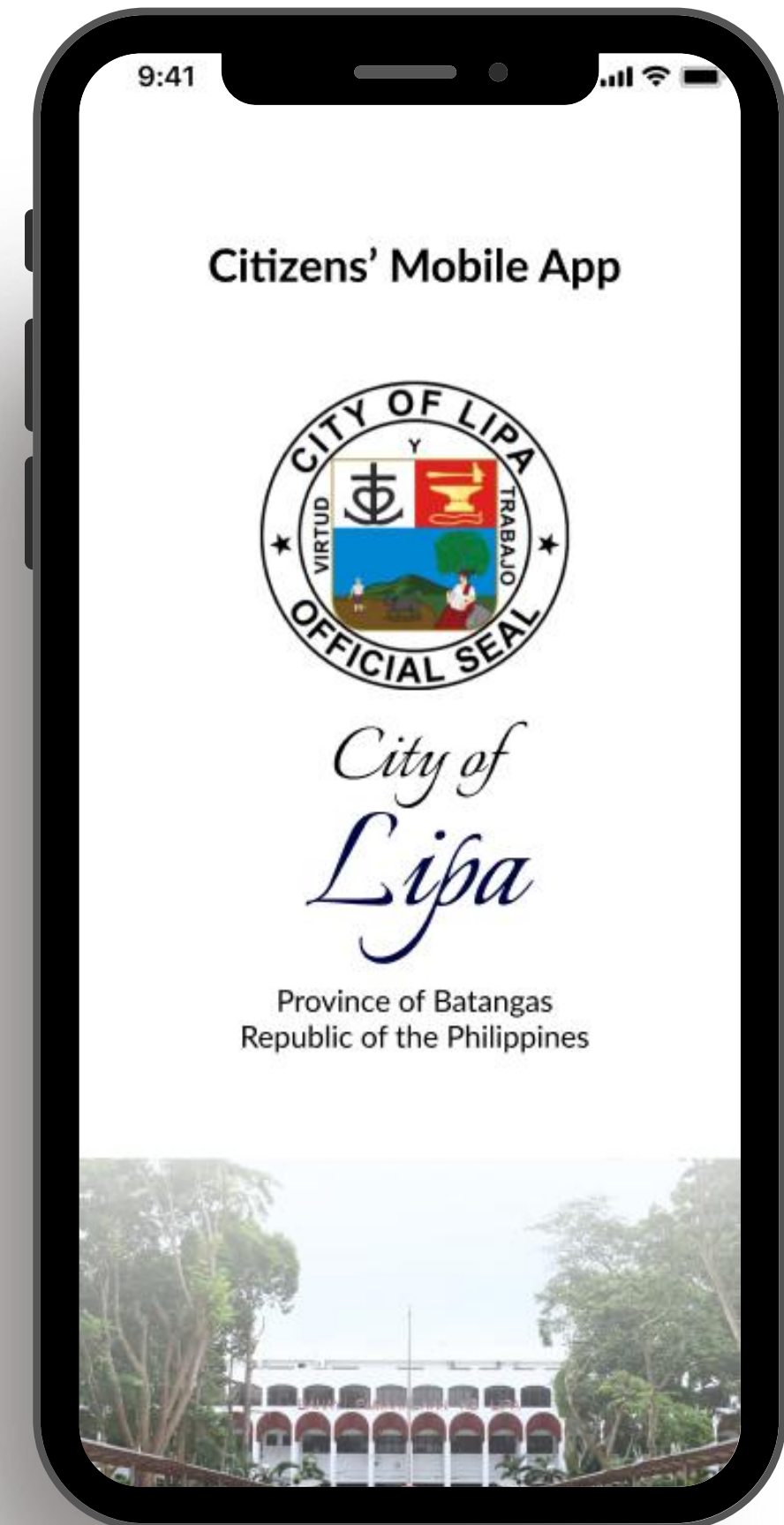

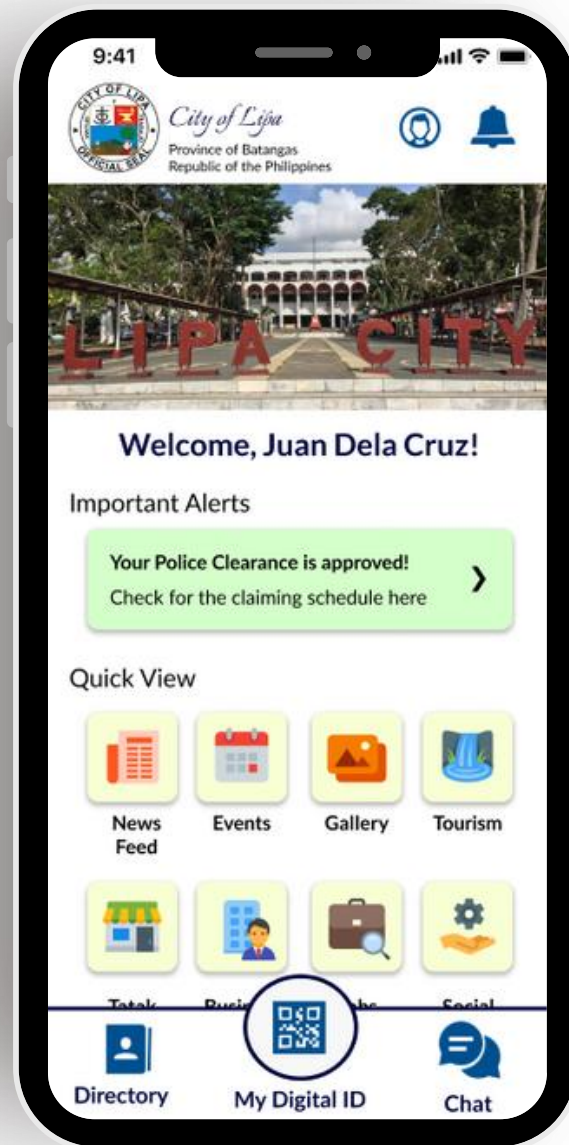

My Profile Page

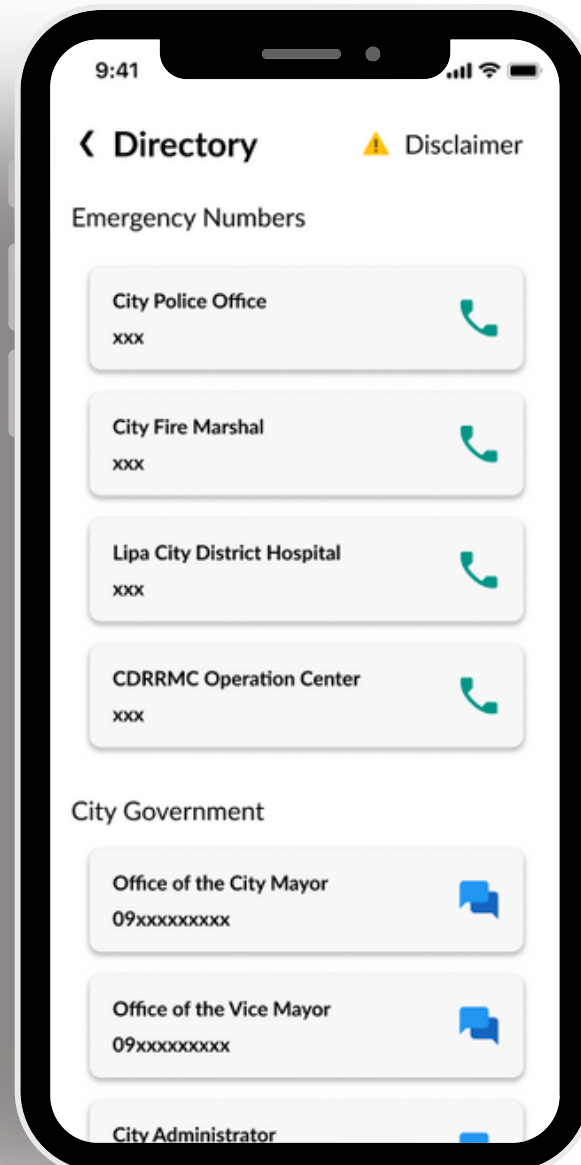

Directory



My Digital ID

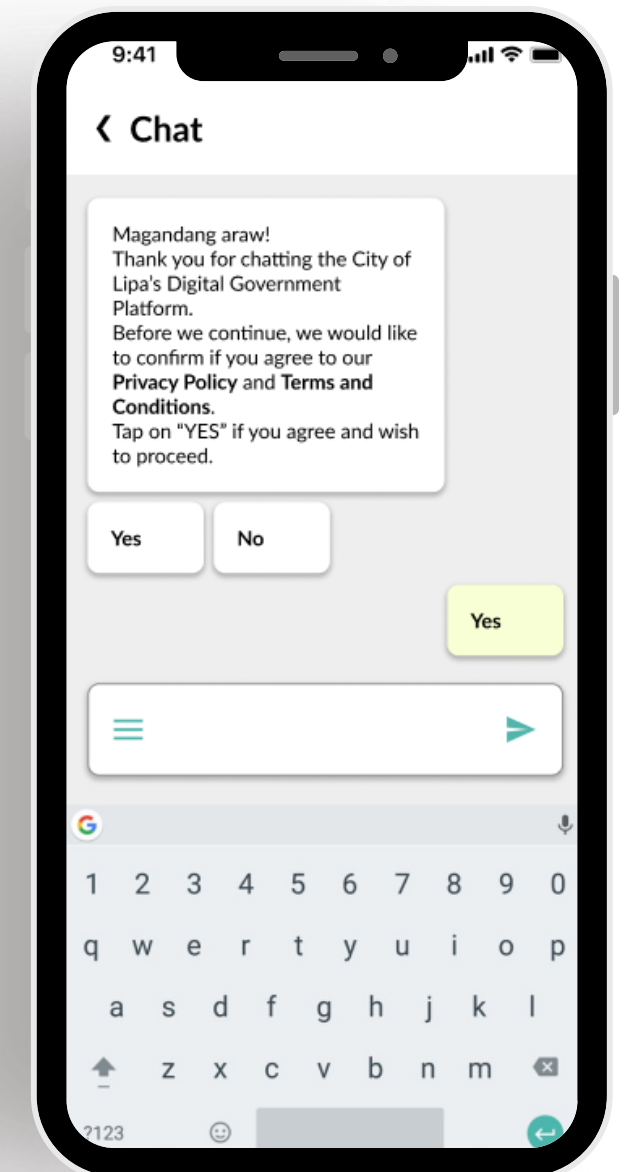

Chat Box

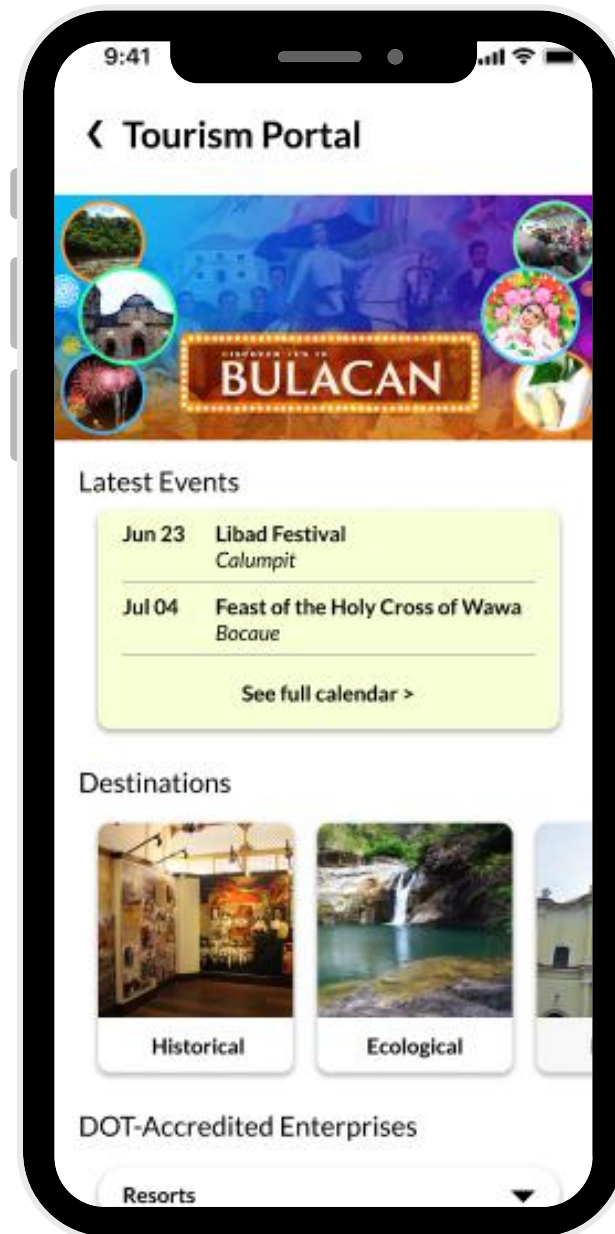

Tourism Portal



Business Directory

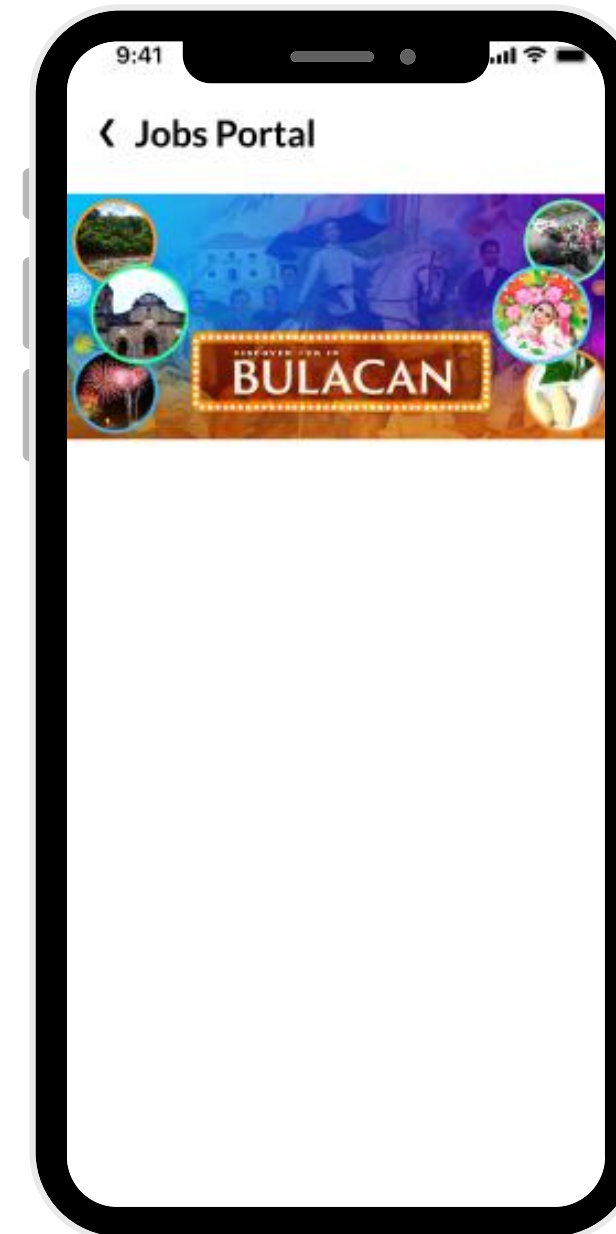

Jobs Portal



my
HAPPYQ
Queuing Management Solution





- **MyHappyQ** is a full-featured and customizable queue management solution designed to streamline customer service for walk-in transactions.
- It allows businesses to efficiently manage and serve customers with minimal wait times through an organized and automated system.



Benefits of my HAPPYQ

Reduced Wait Times:

- Efficiently manages customer flow, minimizing wait times.

Improved Customer Experience:

- Clear communication of expected wait times and progress.

Customizable Workflows:

- Adaptable to various industries with custom transaction types.

Enhanced Service Efficiency:

- Agents handle transactions seamlessly without manual intervention.





How does it work?

Admin

Sets up and assigns queues, agents and operation settings.



Kiosk

Customer inputs basic transaction details and gets a printed queue ticket.



Monitor

Displays queued ticket numbers in real-time, as well as announcements if there is any.



Agent

Manages own queue and transacts with queued customers.



 **TagLink**
RFID-SMS Solution



- **TagLink** is an RFID-SMS solution designed for schools.
- It sends instant SMS alerts to parents or guardians when a student enters or exits the school premises.
- Uses RFID technology for secure and reliable tracking.

Features:

- RFID-based real-time tracking
- Automated SMS notifications for updates
- Workflow customization
- Location-based monitoring

Benefits

- Automate asset tracking processes
- Reduce manual errors and improve accuracy
- Enhance operational efficiency
- Provide real-time updates for better decision-making

How does it work?

RFID Reader

The taps his/her RFID card into the card reader



TagLink Server

The TagLink server processes the RFID tagging operation.



GSM Gateway

The TagLink server processes the RFID tagging operation.



SMS

The Taglink send an SMS to the students' parent/guardian over the telecom network



HelpdeskLink
Ticket Management Solution

Your Ultimate Ticket Management Solution

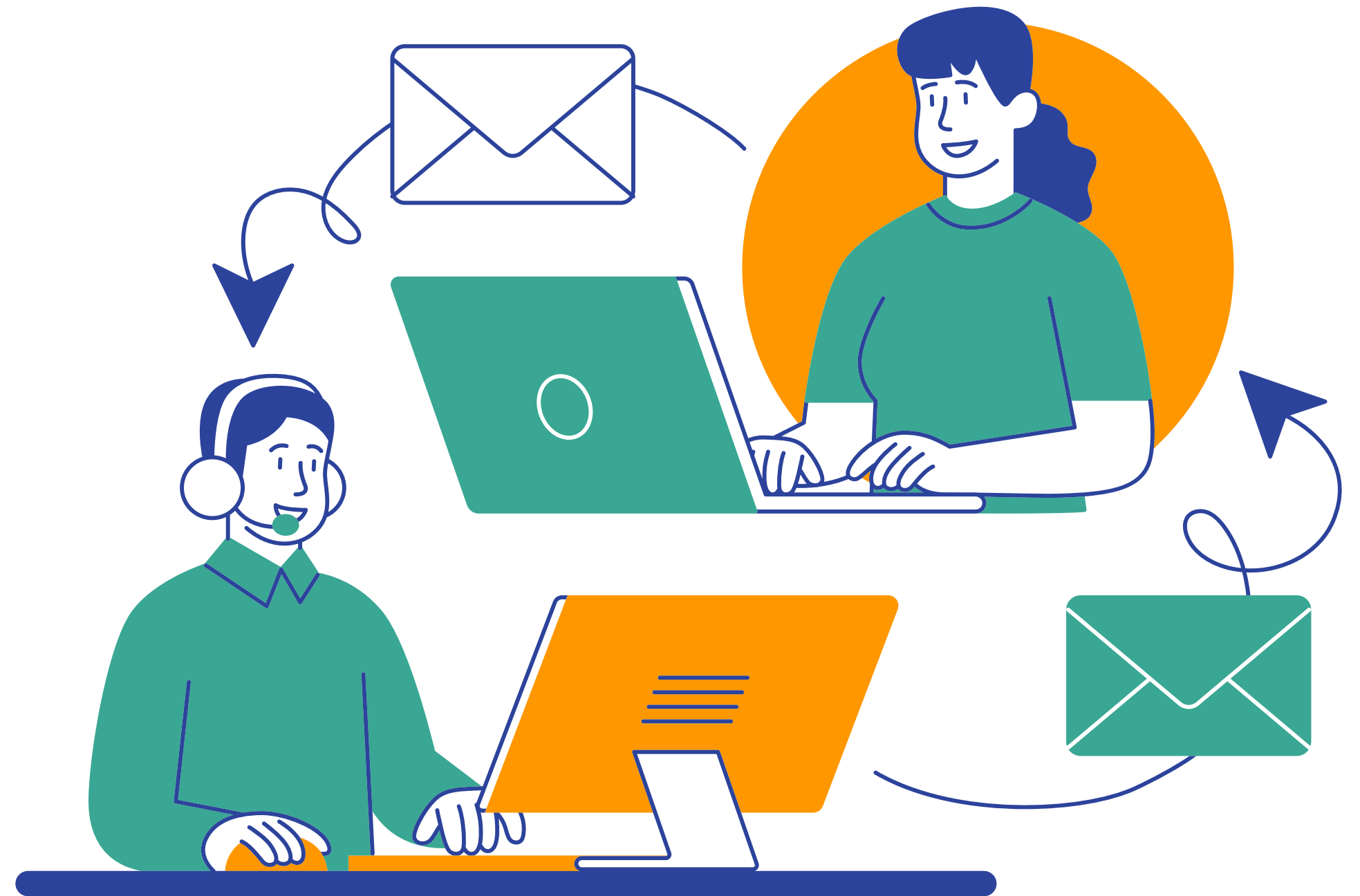



What is HelpdeskLink?

HelpdeskLink is a ticket management solution designed to efficiently manage and resolve customer and internal support requests. With a centralized dashboard, you can track, prioritize, and handle issues in real-time, ensuring no ticket is left unresolved.



How does HelpdeskLink Work?



Ticket Creation: Customers or employees submit issues through various channels (email, chat, web form).

Ticket Assignment: Automatically categorize and assign tickets to the appropriate teams based on the nature of the issue.

Tracking and Resolution: Teams can monitor the progress of each ticket, update statuses, and communicate with the submitter in real-time.

Closing the Loop: Once resolved, feedback is gathered to ensure satisfaction, and analytics reports are generated for management.

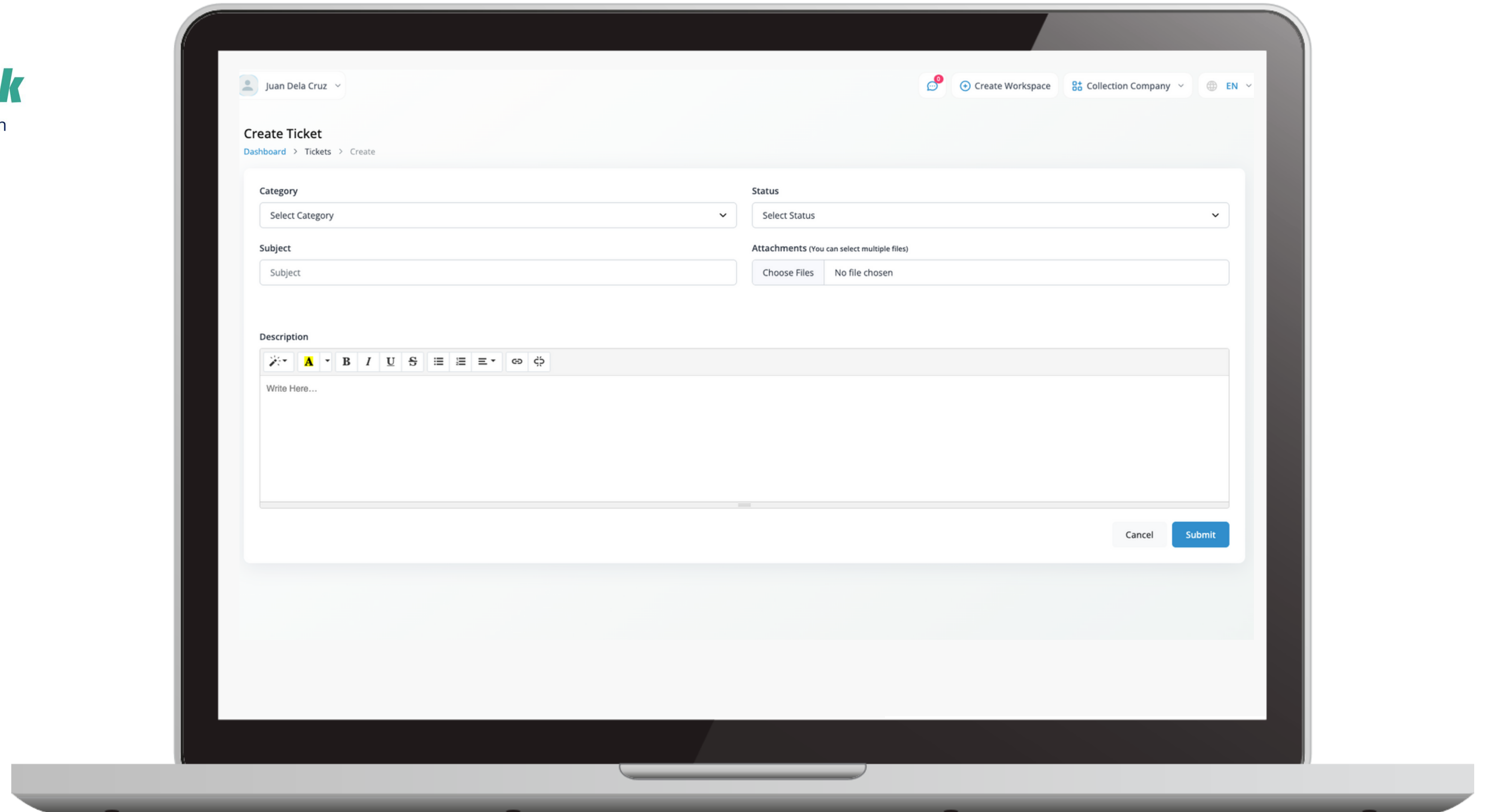



CareLink

Hospital Management Solution





Carelink a full-featured specialized information system software that simplifies, automates and integrates healthcare operations and processes.



Core System of CareLink

- Appointments and Reception Desk
- Outpatient Department (OPD)
- In-patient: Admission, Discharge, Transfer (ADT)
- Rooms and Wards Management
- Emergency Room (ER)
- Operating Room (OR)
- Delivery Room (DR)
- Nursery
- Laboratory
- Radiology
- Blood Bank
- Pharmacy
- Ambulance
- Dietician
- Central Sterile Services Department

- Electronic Medical Record (EMR)
- Staff Task List (Doctors, Nurses etc.)

Billing

- Finance (income and expense reports)
- Inventory and Supplies
- Human Resources (Attendance)
- Third-Party Administrator (TPA)

System Dashboard

- Reports
- User Management for up to 100 users



Core System of CareLink

Hospital Management w/ content management System

- Hospital facilities and services
- Online appointment

Integration

- Philhealth e-claims API (by PHC)
- Online payment gateway
- SMS API

Complimentary Solutions

- SMS broadcasting solution
- Carelink Telemed Platform
- Queuing Management Solution



 **EventLink**

Events Management Solution



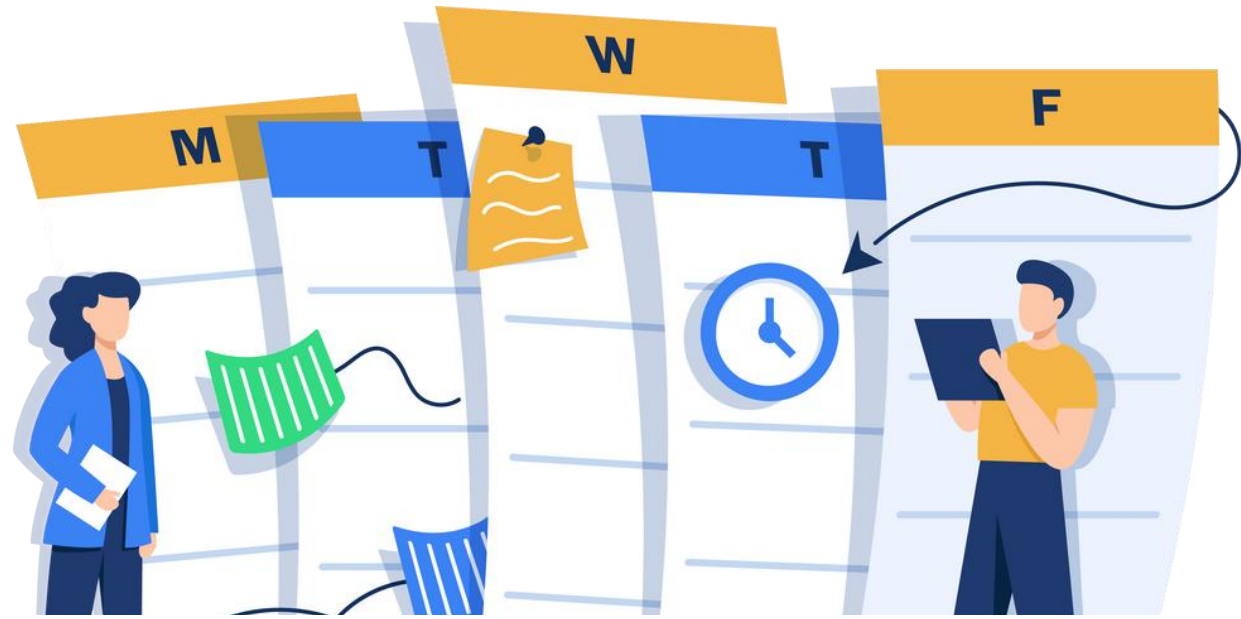

What is EventLink?

EventLink is a powerful and intuitive tool designed to plan, execute, and manage events of any scale. Whether you're hosting a small gathering or a large conference, EventLink streamlines the entire event lifecycle—from seamless registration and ticketing to real-time event coordination and post-event analysis. With its user-friendly interface and robust features, EventLink simplifies the complex process of event management, allowing you to focus on delivering memorable experiences while maximizing efficiency and insights.

Features:

- Online registration and ticketing
- RSVP management tools
- Event scheduling and reminders
- Real-time attendee tracking



Benefits:

- Save time on event planning
- Increase attendee engagement
- Track event success with data analytics
- Minimize manual tasks

 **AcceLink**

Inventory Management Solution





Inventory Management Solution

AcceLink is an advanced inventory management system designed to help businesses monitor, organize, and optimize their inventory levels. It ensures real-time visibility, minimizes manual errors, and helps you avoid stock-related issues.



Features:

- Real-time stock monitoring
- Barcode and QR code scanning integration
- Low-stock and overstock alerts
- Customizable inventory reports



Benefits:

- Minimize stockouts and overstocking issues
- Reduce manual tracking errors
- Increase efficiency in inventory operations
- Enhance decision-making with real-time data



Inventory Management Solution

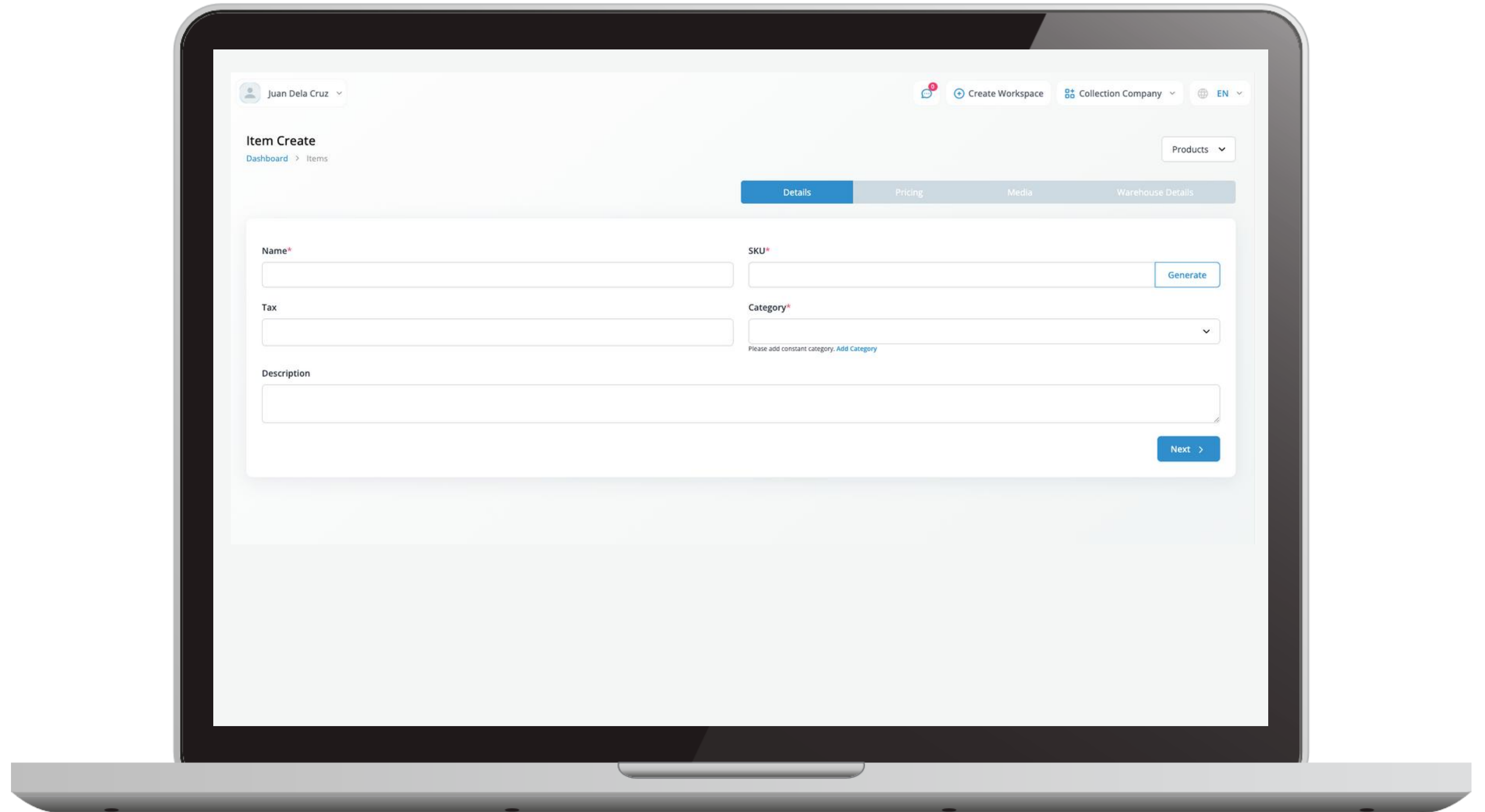

Prop  **Link**
Property Management Solution





PropLink provides a comprehensive platform for managing real estate properties, tenants, and lease agreements. It simplifies workflows for property managers and improves tenant satisfaction.



Features:

- Lease agreement tracking
- Automated billing and invoicing
- Maintenance request management
- Tenant communication portal

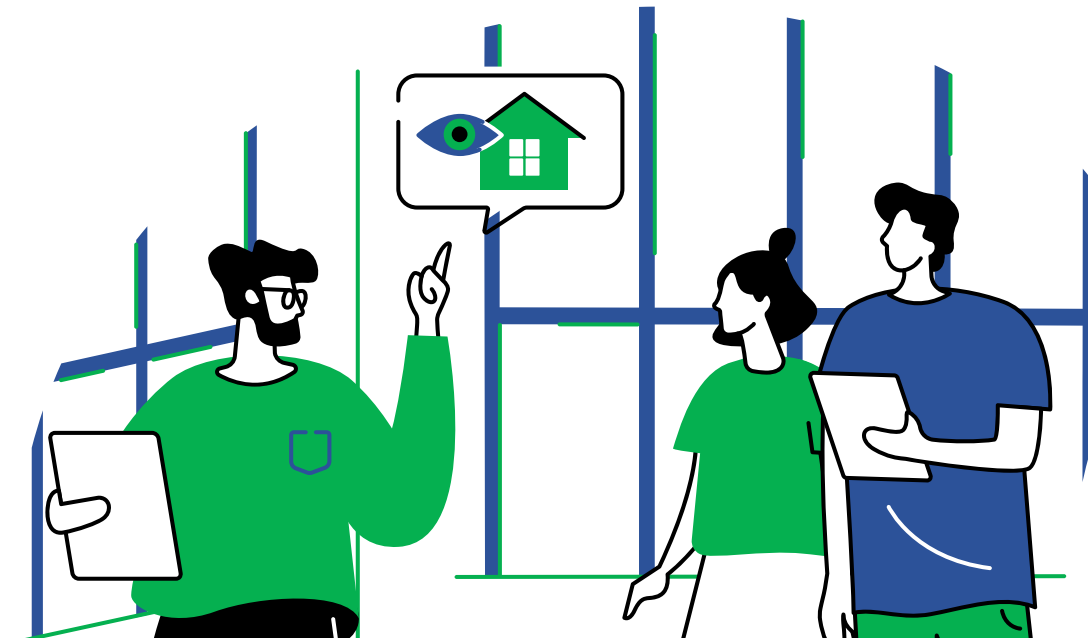

Benefits:

- Improve tenant relationship management
- Save time with automated processes
- Track property performance efficiently
- Reduce errors in billing and lease management

Equip Link

Training Management Solution



EquipLink

Training Management Solution



EquipLink is a comprehensive solution designed to help businesses efficiently manage their training programs, ensuring that employees stay equipped with the skills and knowledge they need to excel in their roles. Whether you're onboarding new team members, offering refresher courses, or providing advanced training, EquipLink simplifies the entire process from planning to execution.

EquipLink enables businesses to create tailored training schedules, track employee progress, and ensure compliance with industry standards. With its intuitive interface and robust features, managers can monitor skill development in real-time, identify areas for improvement, and provide timely feedback.

By streamlining training management, EquipLink not only enhances workforce productivity but also contributes to organizational growth by fostering a culture of continuous learning and professional development. Equip your team with the tools they need to succeed with EquipLink!





Benefits:

- Optimize employee development programs
- Save time on training administration
- Track and analyze training outcomes
- Ensure compliance with certifications

Features:

- Training module creation
- Progress tracking and reporting
- Certification management
- Feedback collection tools





GSM GATEWAY





GSM GATEWAY

A device that connects a Voice over IP (VoIP) network to a mobile GSM network, allowing for communication between the two. It acts as a bridge for sending and receiving voice calls and SMS messages using GSM cellular networks, often providing a more affordable alternative for international calls or high-volume SMS services.



Connection Process

- GSM gateways are connected to the VoIP network and a mobile network via a SIM card.
- Calls and messages are routed through the GSM network.

Key Components

- GSM module
- SIM card slot
- VoIP interface (SIP, H.323, etc.)



VoiceLink - 8 Channels

The VoiceLink 2G-IP08 is an IP- based 8channels GSM Gateway device that enables inbound and outbound of GSM Cellular Calls thru integration to any compatible IP-PBX System. VoiceLink 2G-IP08 may also be used as SMS Gateway VIA an optional SMS Software which are now greatly used for SMS blasting.

Key Features

The VoiceLink 2G-IP08 is an IP- based 8channels GSM Gateway device that enables inbound and outbound of GSM Cellular Calls thru integration to any compatible IP-PBX System. VoiceLink 2G-IP08 may also be used as SMS Gateway VIA an optional SMS Software which are now greatly used for SMS blasting.

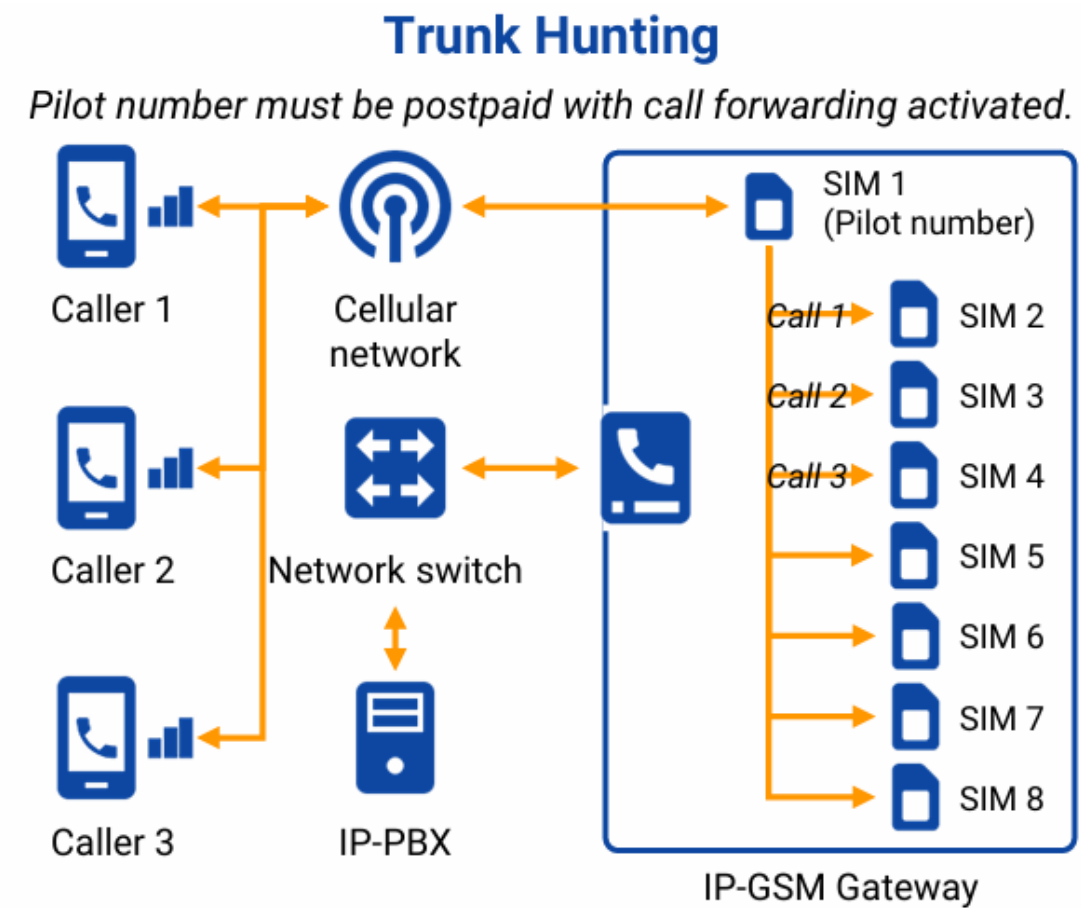



VoiceLink - 16 Channels

The VoiceLink 2G-IP16 is an IP-based 8 channels GSM Gateway device that enables inbound and outbound of GSM Cellular Calls thru integration to any compatible IP-PBX System. VoiceLink 2G-IP16 may also be used as SMS Gateway VIA an optional SMS Software which are now greatly used for SMS blasting.

Key Features

- With GSM Trunk Hunt Feature
- Supports integration to SMS Messaging Software
- Multiple SIM / Open line / Supports any regular SIM
- External antenna interface (x16)
- Compatible with any IP-Based PABX System
- Reduces call costs by directing outgoing mobile calls to GSM Gateway (via the PABX's Least Cost Routing [LCR])

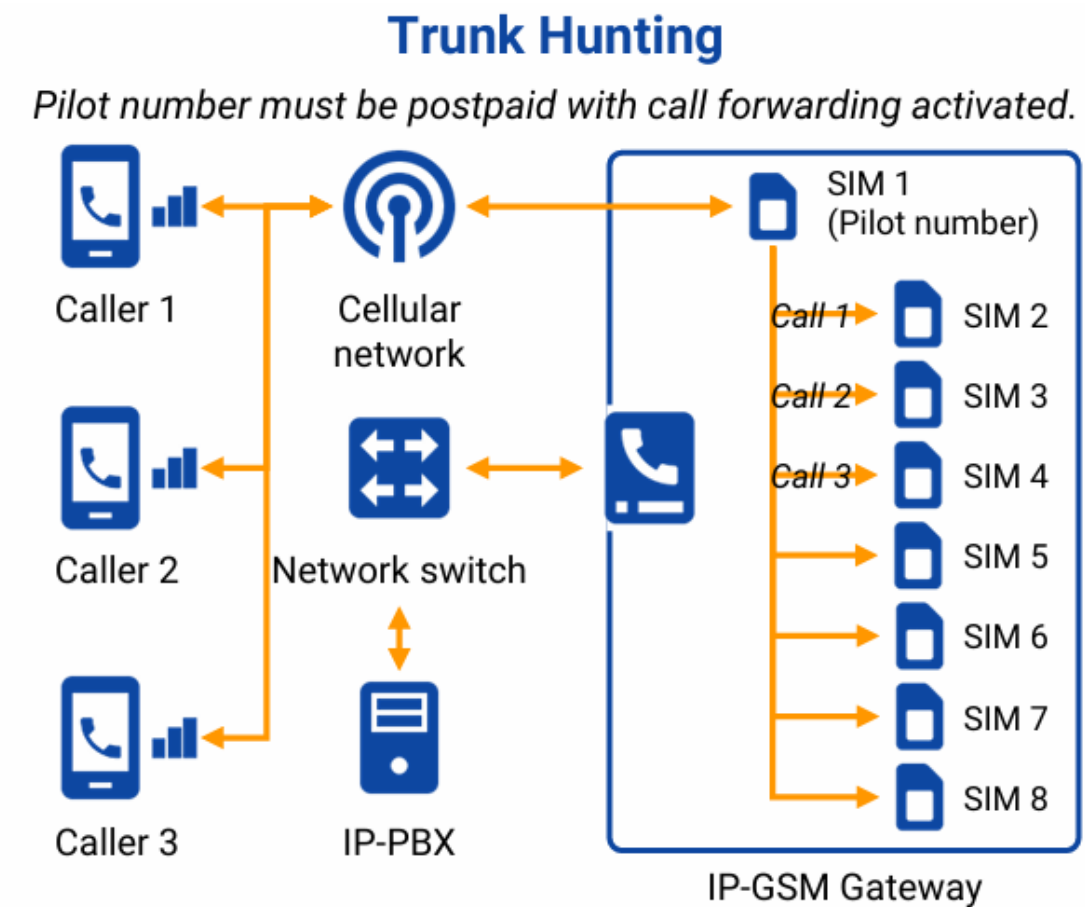



VoiceLink - 32 Channels

The VoiceLink IP-2G32 is an IP-based 32-channel GSM Gateway device that can connect to most compatible IP-PBXs and enable inbound and outbound mobile calls. With its Trunk Hunting feature, use the device's SIM1 channel/port as the pilot number, and it will receive and forward inbound calls to all other active SIMs in the Gateway. This device may also be connected to most SMS broadcasting software that uses SIM cards to send and receive SMS in bulk.

Key Features

- Trunk Hunting
- Reduces call costs by directing outbound mobile calls to GSM Gateway (via the PBX's Least Cost Routing [LCR])
 - Multiple SIMs / Open-line / Supports any regular SIM cards
- External antenna interface (x32)
- Compatible with most IP PBXs with SIP/H.323 Trunk Hunting Pilot number must be postpaid with call forwarding activated. Caller 1 Cellular network Caller 2
- Supports integration with SMS broadcasting software

Trunk Hunting

Pilot number must be postpaid with call forwarding activated.

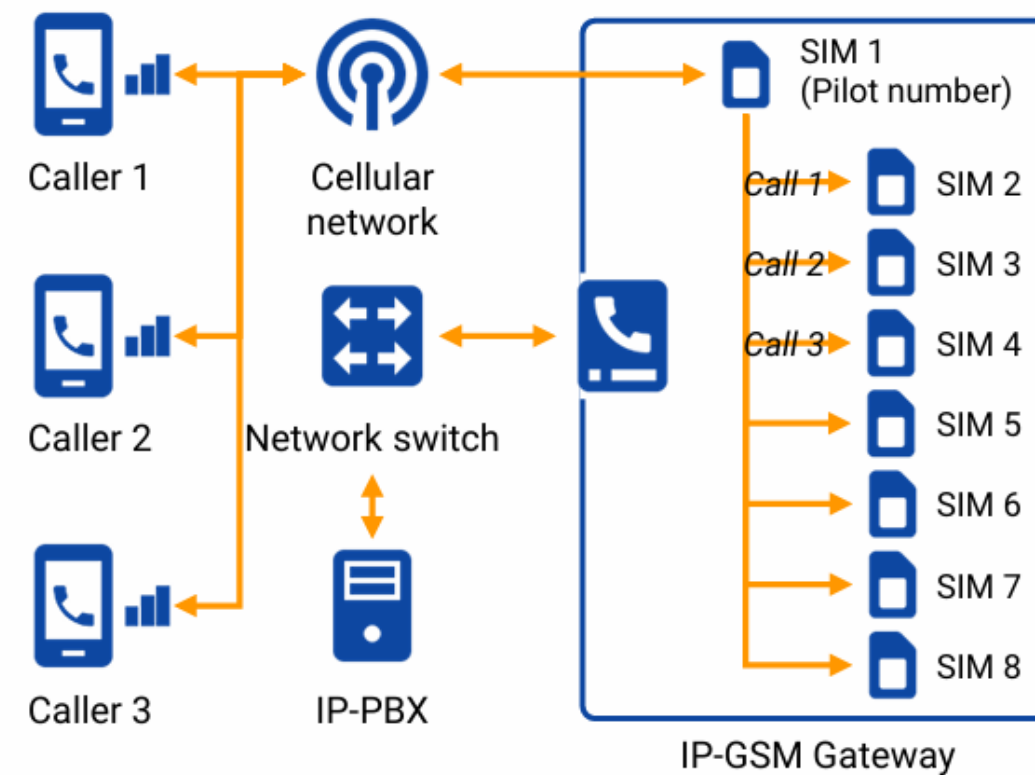



Let's Begin!

MAKING BETTER ICT SOLUTIONS TOGETHER



Phone

+63 2 8731 0817 / +63 2 7274 1963



Website

www.rvnsolutions.com



E-mail

info@rvnsolutions.com



HQ address

44 Molave Rd., Pilar Village, Las Piñas City